

# SERVICE SHEET

19-Jun-2007 10:32:09

**2303922B**



## ⚠ WARNING

**Electrical Shock Hazard**

**Disconnect power before servicing.**

**Replace all parts and panels before operating.**

**Failure to do so can result in death or electrical shock.**

• Normal operating conditions are viewed when the air and temperature controls are at mid-setting, freezer section 0 to -5°F and unit is cycling.

NOTE: Wait and pressure readings will vary and are influenced by the existing condition of the appliance, such as iced-up evaporator, condition of condenser, defrost cycle, pull-down time and customer use.

PERFORMANCE DATA *( NORMAL OPERATING CONDITIONS )				
AMB	WATTS	SYSTEM PRESSURE ( PSIG )		
		HIGH SIDE	LOW SIDE	
70°	140 ± 20	95 ± 20	-7 TO 3	
90°	150 ± 20	135 ± 20	-4 TO 3	
110°	170 ± 20	185 ± 20	-2 TO 4	

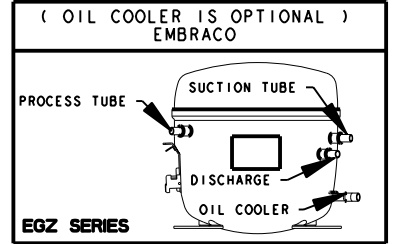

### SERVICE INFORMATION ( 2303916 B )

1. COMPRESSOR SUCTION AND PROCESS STUBS MAY NOT BE INTERCHANGED.
2. REFRIGERANT CHARGE MUST BE APPLIED TO HIGH SIDE ONLY.
3. ICE MAKER AND WATER VALVE NOT ORIGINAL EQUIPMENT ON ALL MODELS.
4. CAUTION: ICE MAKER CYCLE MUST BE INITIATED ELECTRICALLY. DO NOT TRY TO MANUALLY START CYCLE.
5. SERVICE DEFROST BI-METALS -50°F OPEN.
6. DEFROST TIMER MAY CONTAIN A CAPACITOR IN SERIES WITH MOTOR. DO NOT CONTINUITY TEST WHEN CHECKING FOR FAILED TIMER MOTOR. INSTEAD, ENERGIZE TIMER AND LISTEN FOR GEAR MOVEMENT.
7. PART NUMBER CAN BE FOUND ON THE COMPONENT.

### SERVICEABLE ELECTRICAL PARTS MATRIX ( COMPONENTS BY CUBIC FOOT SIZE )

SERVICEABLE PARTS	25 CUBIC FT		WATTAGE	RESISTANCE
	WHIRLPOOL 120 VOLT			
COMPRESSOR	EGZ90	EGZS90	120V	120V
	2255197	2320138		
RUN WINDINGS	*	*		1-5
START WINDINGS	*	*		3-11
START DEVICE, OVERLOAD	2255198	See Note 7		
RUN CAPACITOR ( IF EQUIPPED )	See Note 7			
THERMISTOR	2188819, 2188820			2.7K @ 77°F ( 25°C )
MAIN CONTROL ( Unit compartment )	2304095			
USER INTERFACE	2304103			
DEFROST HEATER	2188175		550-650	27-21
DEFROST BI-METAL	See Note 7			
EVAPORATOR FAN	See Note 7		2-9	
CONDENSER FAN	See Note 7		3-12	

### ELECTRONIC CONTROL FEATURES

The electronic control in this appliance controls the temperatures in the refrigerator and freezer compartments using a single thermistor located in the RC compartment near the airbaffle, delays the operation of the evaporator fan, pulses the defrost heater and monitors the water filter usage. The fan delay and pulsed defrost features are controlled in the following manner:

1. **Evaporator Fan Delay** - The electronic control delays the evaporator fan from coming on for 40 seconds after the compressor has turned on. The evaporator fan stays on for 120 seconds after the compressor has turned off.
2. **Pulsed Defrost Heat** - During the defrost cycle the heater is energized continuously for the first 5 minutes. It is then cycled off for 60 seconds and back on for 120 seconds. This on/off cycle is repeated until the bi-metal opens or the maximum defrost time ( 25 minutes ) is reached.

### COOLING SYSTEM CONTROL SERVICE DIAGNOSTICS MODE

The control system for this product consists of two electronic controls: A main control, which is located in the unit compartment next to the compressor and a user interface board that is located in the upper left side of the Refrigerator compartment. The Service Diagnostic Mode tests the thermistor input and control board outputs. The result of the thermistor check is displayed on the RC display as shown in the table below. In steps 2 through 4, the component tested will be energized and should function if operational.

#### How to enter the Service Mode:

- \*The RC and FC knobs must both be in the off position ( 0 ).
- \*Push in the door switch and turn the RC knob to position 1. When the control first enters the Service Diagnostics mode the FC display will show a "U" and the RC display will show 0-9 for three seconds. This is the revision level of the software in the User Interface board. Then the FC display will change to a "P" and the RC display will show the revision level of the main refrigeration control ( again for 3 seconds prior to entering the Service Diagnostics mode.
- \*Diagnostics will begin at Step No. 1: The FC display is used to indicate the step number of the service diagnostics procedure, and the RC display is used to indicate the status of the test ( where applicable - see table below ).
- \*To advance from one step to the next rotate the Refrigerator control knob clockwise.
- \*The table below shows the component tested at each step.
- \*The diagnostics mode ends automatically after the steps are complete or 20 minutes have passed ( whichever comes first ). The control will then resume normal cooling operation. Please be sure to set the control knobs at the desired location ( typically 4,4 ).

**Service Tip: If the control does not respond it may be necessary to remove power from the entire appliance for a few seconds. Re-apply power and perform the service diagnostics routine to verify that the control is working correctly.**

Step No.	Component Tested	Suggested Diagnostics Routine	FC Display	RC Display
1	RC thermistor	This is an internal board test. The board will check the resistance value of the thermistor and display the results ( P or F ) on the Refrigerator Compartment display.	Step No.	P or F
2	Defrost heater/Bi-metal	Line voltage switched to components from board, verify 120V AC between line and neutral at heater. Note: If Bi-metal is open, it will need to be by-passed for heater to operate. See Warning below.		
3	Evaporator fan motor	Line voltage switched to motor from board, verify 120V AC between line and neutral at motor. Verify 120V AC between white and red/white wires.		
4	Compressor and Condenser fan motor	Line voltage switched to components from board, verify 120V AC between line and neutral at compressor and motor ( red and white wires ).		

The water valve inputs to the control board can be checked when you are in the normal cooling mode. To verify that the water valve inputs are correctly connected to the main control open the Refrigerator door and press in the door switch. Activate the water dispenser and look at the water filter indicator. The green indicator light should be on. Repeating the process above for the icemaker valve would turn the red indicator light on.

**ATTENTION: IF BI-METAL IS BY-PASSED FOR TESTING ( IF APPLICABLE ), DO NOT OVERHEAT EVAPORATOR AREA.**

SERVICE SHEET NO.	SERVICE SHEET NO.
<b>2303922B</b>	<b>2303922B</b>

# SERVICE SHEET

19-Jun-2007 10:32:09



⚠ WARNING

Electrical Shock Hazard

Disconnect power before servicing.  
Replace all parts and panels before operating.  
Failure to do so can result in death or electrical shock.

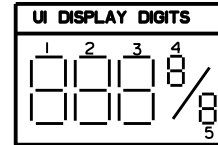

## SERVICE INFORMATION ( 2303912 B

### ELECTRONIC DISPENSER CONTROL FEATURES

The electronic dispenser control in this appliance controls ice and water dispensing, directs icemaker water fills upon request from the icemaker system, monitors the water filter usage, and controls the operation of the dispenser cavity lighting and dispenser housing heater.

### SERVICE DIAGNOSTICS MODE

The dispenser control system consists of three electronic controls: A Dispenser Core Control which is located behind the dispenser bezel assembly, a Dispenser UI Control which is attached to the back portion of the dispenser bezel assembly, and a Smart Valve which is located within the unit compartment. The Service Diagnostic Mode tests the functionality of the dispensing system. The dispenser control system automatically tests steps 0, 1, 3, 4, 7, 10, 15, 18, and 19. Steps 5, 6, 12, 14, and 20 require manual interaction with the technician.

#### How to Enter Service Diagnostic Mode:

- Unit must not be in Lockout prior to entering Service Diagnostic Mode.
- While depressing the CUBED button, press and hold the LIGHT button for about 3 seconds, then release both buttons after the unit beeps.
- Diagnostics will begin in Step 0. Each step displays the step number in the two right-most digits (Digits 4 and 5) of the UI dispenser display and the step result using the first three digits (Digits 1 to 3) as described in the Suggested Diagnostic Routine for each step.
- Each step must be manually advanced by pressing the LOCKOUT button to move to the next step in the sequence or retreated to the previous step by pressing the FILTER RESET button.
- All button and pad inputs shall be ignored and all outputs shall be off, except as described in the actions for each step.
- The table below shows the component tested of each step. Ignore steps for which the component tested is N/A.
- If communication is lost with the Dispenser Core Control, Steps 10 through 14 will display "- - -" on Digits 1 to 3
- If communication is lost with the Smart Valve Control, Steps 15 through 20 will display "- - -" on Digits 1 to 3
- The diagnostic mode ends automatically after the steps are complete or 20 minutes have passed (whichever comes first). Diagnostic mode can also be manually exited by pressing the LIGHT button during any step or in the case that electrical power is cycled. Following the exit of diagnostic mode, the controls will then resume normal operation.

Step #	Component Tested	Suggested Diagnostics Routine	Component Status Indicator
0	All UI indicators	Verify that all LED indicators, UI display digits, and dispenser lighting turn on automatically	N/A
1	Dispenser UI Control SW Version	Displays the Dispenser UI Control software version on Digits 1 to 3 of the UI display	N/A
2	N/A	N/A	N/A
3	Water Filter Usage Rating	Displays the total water usage rating in gallons for the water filter on Digits 1 to 3 of the UI display	200
4	Water Filter Time Rating	Displays the total time rating in days for the water filter on Digits 1 to 3 of UI display	182
5	UI Pad and Button Test	Note: Do not use <b>LOCKOUT</b> , <b>FILTER RESET</b> and <b>LIGHT</b> as these buttons are only used to control the Service Diagnostic Mode as previously described. Displays the status of both Water and Ice pads on Digit 1. Depress the pads in all combinations to verify the appropriate status indications as shown in the Component Status Indicator Column. Displays the UI Button matrix on Digits 2 and 3. Depress each UI button to verify the appropriate status indications as shown in the Component Status Indicator column.	<b>Digit 1:</b> Ice Pad "1" Water Pad "2" Ice & Water Pad "3" <b>Digits 2 and 3:</b> + "13" CRUSHED "14" CONTAINER "22" UNITS "23" CUBED "24" MEASURED FILL "32" - "33" WATER "34"
6	Night Light Sensor	Displays the Night Light Sensor reading on Digits 1 to 3 of UI display. Cover the sensor to verify a decrease in the result.	N/A
7	Dispenser Lighting	Verify that the dispenser lighting cycles between Maximum and Minimum output levels.	N/A
8	Dispenser Housing Heater Status	Digit 3 must read "1". Press <b>CUBED</b> to change.	<b>Digit 3:</b> Housing Heater Off "0" Housing Heater On "1"
9	N/A	N/A	N/A
10	Dispenser Core Control SW Version	Displays the Dispenser Core Control software version on Digits 1 to 3 of the UI display.	N/A
11	N/A	N/A	N/A
12	FC Door Switch Input	Displays the FC Door status in realtime on Digit 3 of the UI display. Verify that the open and close status display correctly	FC Door Closed "0" FC Door Open "1"
13	N/A	N/A	N/A
14	Ice Door Motor	Displays the Ice Door stepper motor state on Digit 3 of the UI display. Initiate ice dispense and verify that the mechanical operation of the Ice Door corresponds in the component status indicator. Note: Ice Door will close 10 sec. following release of Ice Pad. Ice will dispense upon Ice Pad depressing	Ice Door Closed "0" Ice Door Opening "1" Ice Door Open "2" Ice Door Closing "3"
15	Smart Valve SW Version	Displays the Smart Valve software version on Digits 1 to 3 of the UI display.	N/A
16	N/A	N/A	N/A
17	N/A	N/A	N/A
18	Water Filter Usage	Displays the current water filter status in gallons used since last reset on Digits 1 to 3	0 to 999
19	Water Filter Time	Displays the current water filter status in days since last reset on Digits 1 to 3	0 to 999
20	Water Dispensing and Icemaker Fill Test	Displays Icemaker status on Digit 1. Initiate icemaker fill and verify that display changes from "0" to "3". If a water dispense is in progress while the icemaker fill is initiated, the display will change to "1". Once the water dispense is complete, the icemaker fill will begin and the display will change to "3" as long as it is not interrupted by a water dispense.  Displays water valve status on Digit 2 and flowsensor status on Digit 3. Initiate water dispense and verify Digit 2 changes to "1" and Digit 3 remains "0" during water dispense	<b>Digit 1:</b> Icemaker Off "0" Icemaker Fill Pending "1" Icemaker Filling "3" <b>Digit 2:</b> Water Dispenser Valve Off "0" Water Dispenser Valve On "1" <b>Digit 3:</b> Flowsensor Okay "0" Flowsensor Failed "1"

1. SMART VALVE SOLENOIDS GROUNDED THROUGH MOUNTING.
2. EVAP COVER GROUNDED THROUGH HEAT SHIELD.
3. THE DEFROSTER CONTROL HAS 8 BUILT IN INVERTER BOARD WHICH CONVERTS THE 120VAC TO 120VDC. THE BROWN AND RED/WHITE SWITCH POLARITY DEPENDS ON CROSSFLOW POSITION. SEE TABLE BELOW.



**WARNING**

**Electrical Shock Hazard**

**Disconnect power before servicing.**

**Replace all parts and panels before operating.**

**Failure to do so can result in death or electrical shock.**

**WIRING DIAGRAM**

**WIRE COLOR CODE**

WH/GN = WHITE/GREEN TRACER  
OR/BN = ORANGE/BLACK TRACER  
YL/RD = YELLOW/RED TRACER  
BU/BN = BLUE/BLACK TRACER  
WH/BU = WHITE/BLUE TRACER  
BK/YL = BLACK/YELLOW TRACER  
WH/RD = WHITE/RED TRACER  
GN/YL = GREEN/YELLOW TRACER  
BK/WH = BLACK/WHITE TRACER  
YL/BN = YELLOW/BLACK TRACER  
PK/BN = PINK/BLACK TRACER  
BR/WH = BROWN/WHITE TRACER  
OR/BU = ORANGE/BLUE TRACER  
RD/WH = RED/WHITE TRACER  
LB/BN = LIGHT BLUE/BLACK TRACER  
TN/WH = TAN/WHITE TRACER  
RD/YL = RED/YELLOW TRACER  
BU/YL = BLUE/YELLOW TRACER  
V/WH = VIOLET/WHITE TRACER

**WIRE COLOR CODE**

BU = BLUE  
BK = BLACK  
RD = RED  
WH = WHITE  
YL = YELLOW  
OR = ORANGE  
BR = BROWN  
GN = GRAY  
PK = PINK  
V = VIOLET  
TN = TAN

**WIRE COLOR CODE**

BU = BLUE  
BK = BLACK  
RD = RED  
WH = WHITE  
YL = YELLOW  
OR = ORANGE  
BR = BROWN  
GN = GRAY  
PK = PINK  
V = VIOLET  
TN = TAN

MANUFACTURED UNDER ONE OR MORE OF THE FOLLOWING UNITED STATES PATENTS

3,960,631	4,659,157	4,765,696	4,908,544	5,011,101
4,084,725	4,665,708	4,787,896	4,911,508	5,033,182
4,090,641	4,694,553	4,768,353	4,914,928	5,033,273
4,102,660	4,706,169	4,776,178	4,920,758	5,042,398
4,327,567	4,707,401	4,787,216	4,924,680	5,044,104
4,330,310	4,709,556	4,799,362	4,934,541	5,050,777
4,640,432	4,715,512	4,800,935	4,936,641	5,070,708
4,649,712	4,728,759	4,801,181	4,944,566	5,071,985
4,649,717	4,745,656	4,833,894	4,958,890	D309,461
4,649,718	4,745,775	4,862,577	4,996,848	

- SYMBOL CODE**
- : CONNECTOR - SCREW ON
  - ⊙ : CONNECTOR - CLOSED END
  - : DISCONNECT TERMINAL
  - : PERMANENT CONNECTION
  - ⊚ : PLUG CONNECTOR
  - ⊞ : GROUND ( CHASSIS )

OTHER PATENTS PENDING

WIRING SHEET NO. W10142180A

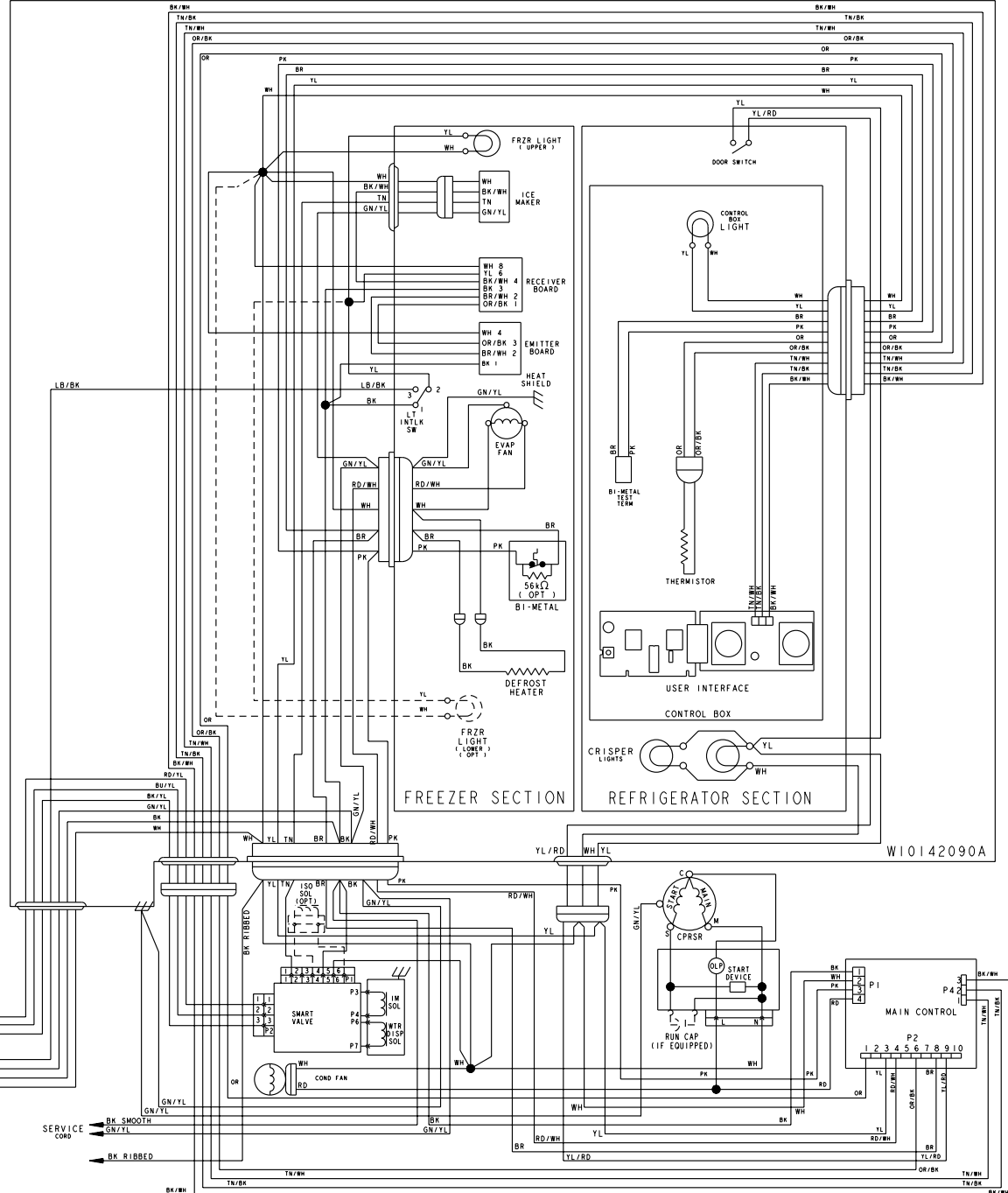
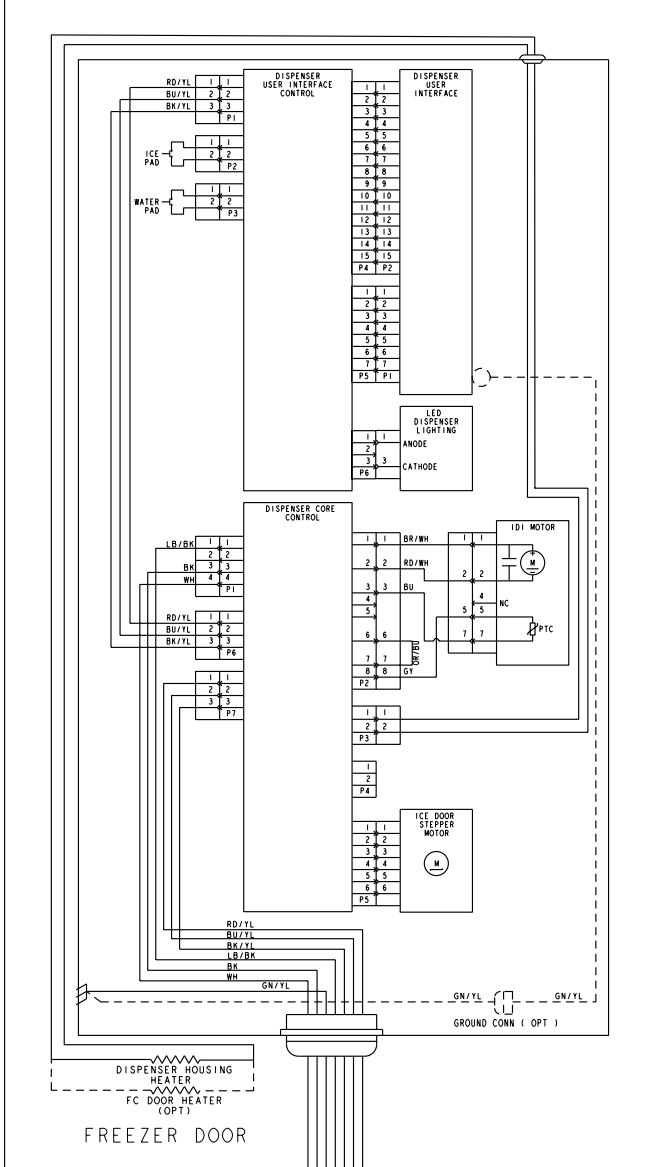

- SMART VALVE SOLENOIDS GROUNDED THROUGH MOUNTING.
- EVAP COVER GROUNDED THROUGH HEAT SHIELD.
- THE DISPENSER CONTROL HAS A BUILT IN INVERTER BOARD WHICH CONVERTS THE AC VOLTAGE TO 120V DC. THE BR/WH AND RD/WH WIRES SWITCH POLARITY DEPENDING ON CRUSH/CODE POSITION. SEE TABLE BELOW:

CRUSH	BR/WH	RD/WH
CUBE	*	*

## ⚠ WARNING

**Electrical Shock Hazard**

**Disconnect power before servicing.**

**Replace all parts and panels before operating.**

**Failure to do so can result in death or electrical shock.**

### WIRING DIAGRAM

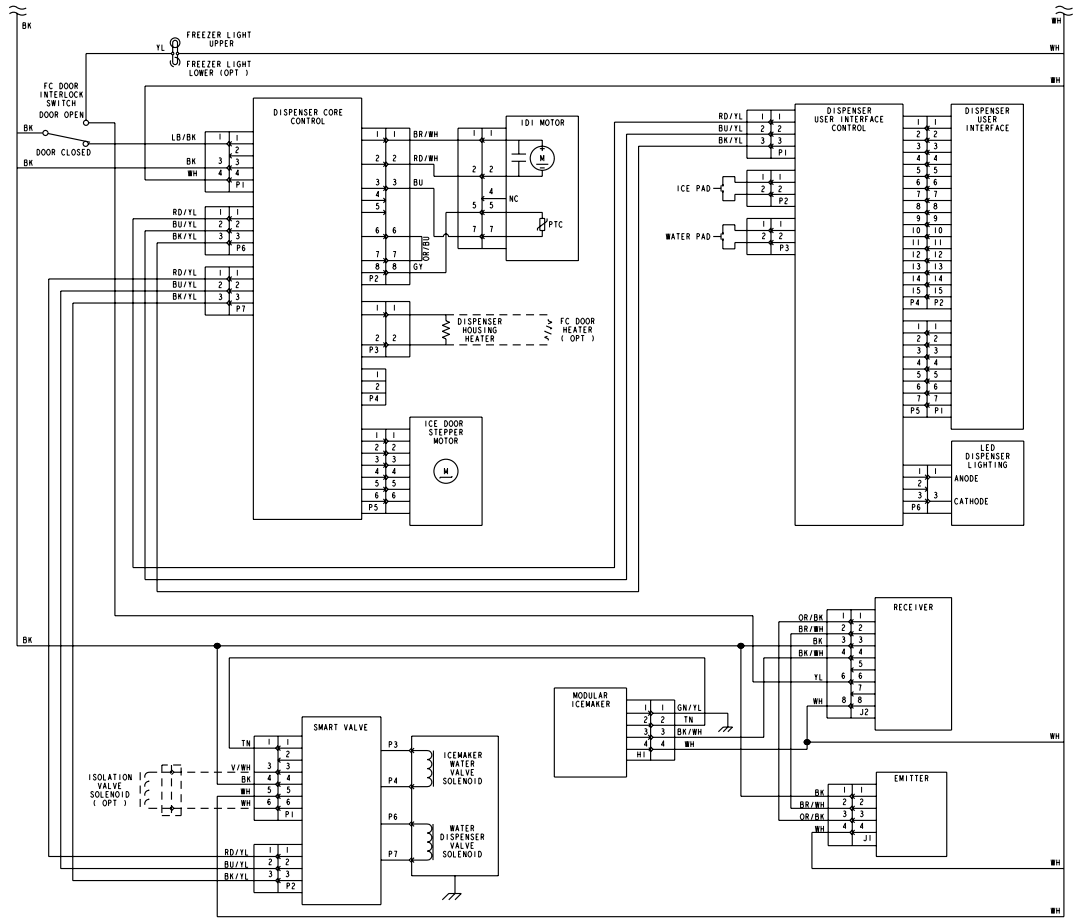
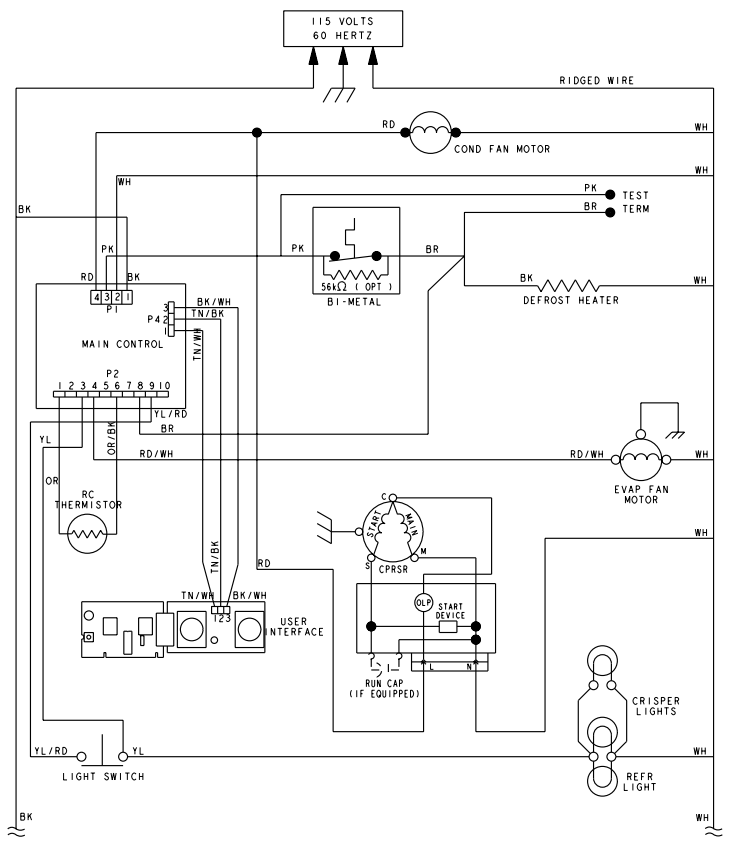

- |                                 |             |
|---------------------------------|-------------|
| WH/GN = WHITE/GREEN TRACER      | BU = BLUE   |
| OR/BK = ORANGE/BLACK TRACER     | BK = BLACK  |
| YL/RD = YELLOW/RED TRACER       | RD = RED    |
| BU/BK = BLUE/BLACK TRACER       | WH = WHITE  |
| WH/BU = WHITE/BLUE TRACER       | YL = YELLOW |
| BR/YL = BLACK/YELLOW TRACER     | OR = ORANGE |
| WH/RD = WHITE/RED TRACER        | BR = BROWN  |
| GN/YL = GREEN/YELLOW TRACER     | GY = GRAY   |
| BR/WH = BLACK/WHITE TRACER      | PK = PINK   |
| YL/BK = YELLOW/BLACK TRACER     | V = VIOLET  |
| PK/BK = PINK/BLACK TRACER       | TN = TAN    |
| BR/WH = BROWN/WHITE TRACER      |             |
| OR/BU = ORANGE/BLUE TRACER      |             |
| RD/WH = RED/WHITE TRACER        |             |
| LB/WH = LIGHT BLUE/BLACK TRACER |             |
| TN/WH = TAN/WHITE TRACER        |             |
| RD/YL = RED/YELLOW TRACER       |             |
| RD/YL = RED/YELLOW TRACER       |             |
| V/WH = VIOLET/WHITE TRACER      |             |

MANUFACTURED UNDER ONE OR MORE  
OF THE FOLLOWING UNITED STATES PATENTS

3,960,631 4,659,157 4,765,696 4,908,544 5,011,101  
 4,084,725 4,665,708 4,767,896 4,911,508 5,033,182  
 4,090,641 4,694,553 4,768,353 4,914,928 5,033,273  
 4,102,860 4,706,169 4,776,178 4,920,758 5,042,398  
 4,327,557 4,707,401 4,787,216 4,924,680 5,044,704  
 4,330,310 4,709,556 4,799,362 4,934,541 5,050,777  
 4,640,432 4,715,512 4,800,335 4,936,641 5,070,708  
 4,649,712 4,728,759 4,801,181 4,944,566 5,077,985  
 4,649,717 4,745,656 4,833,894 4,958,890 5,009,461  
 4,649,718 4,745,775 4,862,371 4,936,848

- SYMBOL CODE
- ⊙ : CONNECTOR - SCREW ON
  - ⊕ : CONNECTOR - CLOSED END
  - : DISCONNECT TERMINAL
  - : PERMANENT CONNECTION
  - ⊘ : PLUG CONNECTOR
  - ⊔ : GROUND ( CHASSIS )

OTHER PATENTS PENDING